

DAYLITE OPENINGS:  
 D.L.O. HEIGHT = PANEL HEIGHT - 8.875"  
 D.L.O. WIDTH = PANE  
 PANEL HEIGHT = DOOR HEIGHT - 2"

THESE DOORS ARE RATED FOR LARGE & SMALL MISSILE IMPACT.  
 SHUTTERS ARE NOT REQUIRED.

**ATLANTIC SERIES LM 130 ALUM SLIDING GLASS DOOR**

SEE SHEET 2 FOR DESIGN LOAD CAPACITY OF DESIRED GLASS/REINF.  
 USING CHART ON SHEET 3 SELECT ANCHOR OPTION WITH DESIGN  
 RATING MORE THAN DESIGN LOADS REQUIRED.  
 LOWER DESIGN PRESSURES FROM GLASS OR ANCHOR CHARTS  
 WILL APPLY TO ENTIRE SYSTEM.

THIS PRODUCT HAS BEEN DESIGNED AND TESTED TO COMPLY WITH THE  
 REQUIREMENTS OF THE 2020 (7TH EDITION)/2023 (8TH EDITION) FLORIDA  
 BUILDING CODE INCLUDING HIGH VELOCITY HURRICANE ZONE (HVHZ).

1BY OR 2BY WOOD BUCKS & BUCK FASTENERS BY OTHERS, MUST BE  
 DESIGNED AND INSTALLED ADEQUATELY TO TRANSFER APPLIED PRODUCT  
 LOADS TO THE BUILDING STRUCTURE.

ANCHORS SHALL BE CORROSION RESISTANT, SPACED AS SHOWN ON DETAILS  
 AND INSTALLED PER MANUF'S INSTRUCTIONS. SPECIFIED EMBEDMENT TO BASE  
 MATERIAL SHALL BE BEYOND WALL DRESSING OR STUCCO.

A LOAD DURATION INCREASE IS USED IN DESIGN OF ANCHORS INTO WOOD ONLY.  
 ALL SHIMS TO BE HIGH IMPACT, NON-METALLIC AND NON-COMPRESSIBLE.

MATERIALS INCLUDING BUT NOT LIMITED TO STEEL/METAL SCREWS, THAT  
 COME INTO CONTACT WITH OTHER DISSIMILAR MATERIALS SHALL MEET THE  
 REQUIREMENTS OF THE 2020/2023 FLORIDA BLDG. CODE & ADOPTED STANDARDS.

THIS PRODUCT APPROVAL IS GENERIC AND DOES NOT PROVIDE INFORMATION  
 FOR A SITE SPECIFIC PROJECT, i.e. LIFE SAFETY OF THIS PRODUCT, ADEQUACY  
 OF STRUCTURE RECEIVING THIS PRODUCT AND SEALING AROUND OPENING FOR  
 WATER INFILTRATION RESISTANCE ETC.  
 CONDITIONS NOT SHOWN IN THIS DRAWING ARE TO BE ANALYZED SEPARATELY,  
 AND TO BE REVIEWED BY BUILDING OFFICIAL.

DESIGN LOADS SHOWN ARE BASED ON 'ALLOWABLE STRESS DESIGN (ASD)'

MANUFACTURER'S LABEL SHALL BE LOCATED ON A READILY VISIBLE LOCATION  
 IN ACCORDANCE WITH SECTION 1709.9.3 OF FLORIDA BUILDING CODE.  
 LABELING TO COMPLY WITH SECTION 1709.9.2.

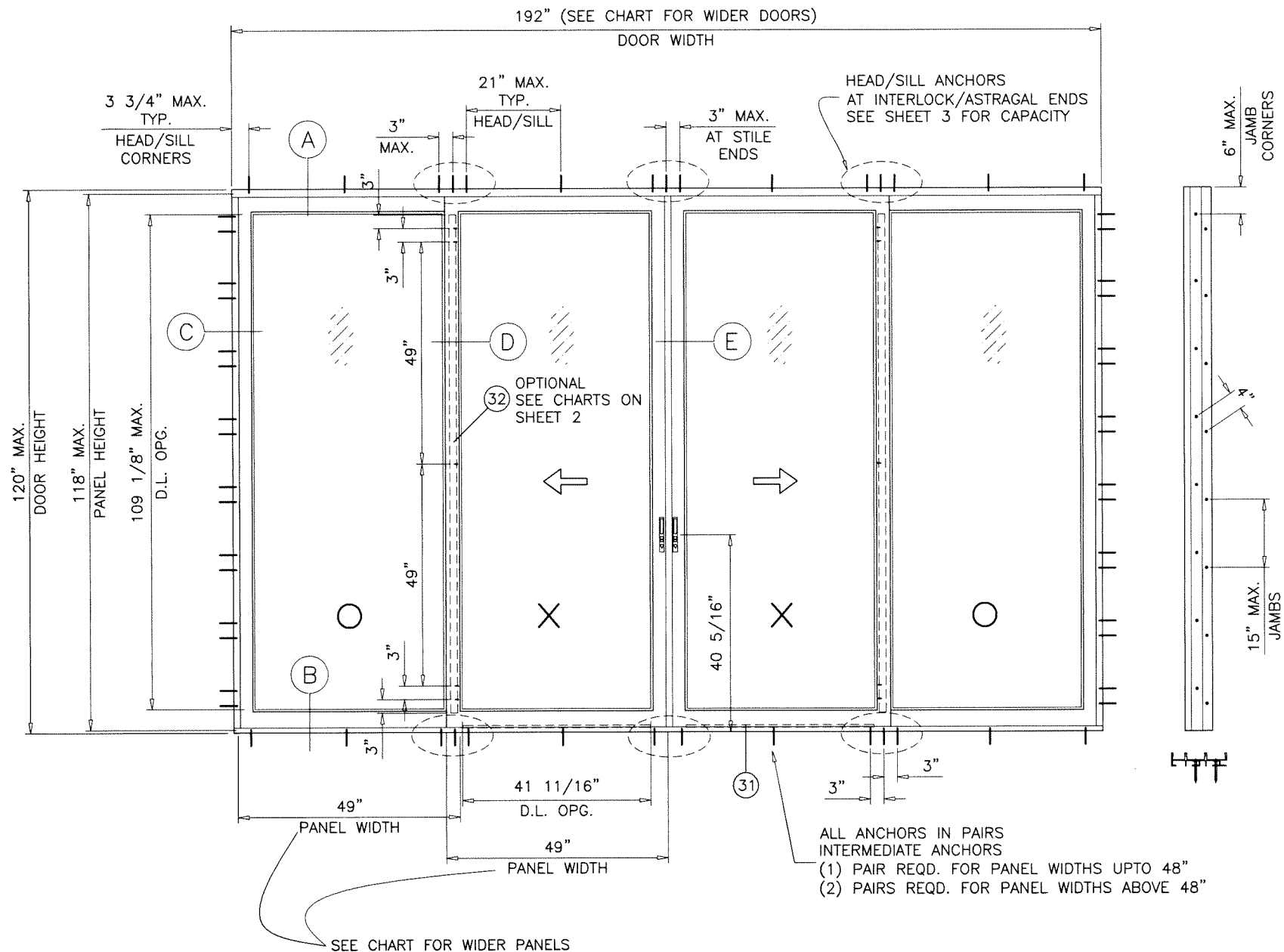

TYPICAL ELEVATION  
 TESTED UNIT

JAMB ANCHOR SPACING  
 15" MAX. FOR INSTALLATIONS INTO CONC., WOOD  
 AND METAL STRUCTURES

ALL DOOR INSTALLATIONS MUST BE IN ACCORDANCE WITH  
 EGS INSTALLATION INSTRUCTIONS.  
 ALL SEALANTS TO BE TREMCO SPECTREM 2 OR EQUAL.  
 (EQUAL SEALANTS MUST BE TESTED BY SEALANT  
 MANUFACTURER FOR COMPATIBILITY & ADHESION). Sealed: 7/12/2023 FL #29677

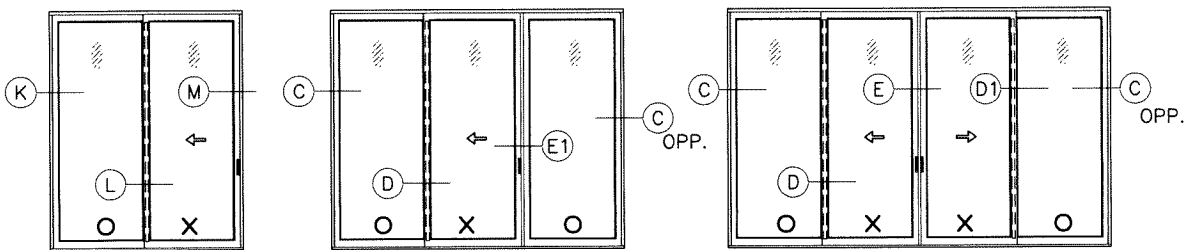

APPROVED CONFIGURATIONS

- A- CONTRACTOR TO BE RESPONSIBLE FOR THE SELECTION, PURCHASE AND  
 INSTALLATION OF THIS PRODUCT BASED ON THIS PRODUCT EVALUATION  
 PROVIDED HE/SHE DOES NOT DEVIATE FROM THE CONDITIONS DETAILED ON  
 THIS DOCUMENT.
- B- THIS PRODUCT EVALUATION DOCUMENT WILL BE CONSIDERED INVALID IF  
 ALTERED BY ANY MEANS.
- C- SITE SPECIFIC PROJECTS SHALL BE PREPARED BY A FLORIDA REGISTERED  
 ENGINEER OR ARCHITECT WHICH WILL BECOME THE ENGINEER OF RECORD (E.O.R.)  
 FOR THE PROJECT AND WHO WILL BE RESPONSIBLE FOR THE PROPER  
 USE OF THE P.E.D. ENGINEER OF RECORD, ACTING AS A DELEGATED  
 ENGINEER TO THE P.E.D. ENGINEER SHALL SUBMIT TO THIS LATTER THE SITE  
 SPECIFIC DRAWINGS FOR REVIEW.
- D- THIS P.E.D. SHALL BEAR THE DATE AND ORIGINAL SEAL AND SIGNATURE OF  
 THE PROFESSIONAL ENGINEER OF RECORD THAT PREPARED IT.

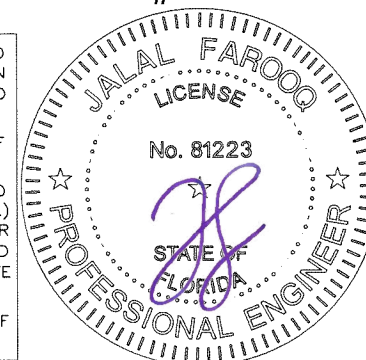

**af c**  
**AL-FAROOQ CORPORATION**  
 ENGINEERS & PRODUCT DEVELOPMENT  
 9360 SUNSET DRIVE, SUITE 220 (C.A.N. 3538)  
 MIAMI, FLORIDA 33173 FAX. (305) 262-6978  
 TEL. (305) 264-8100

ATLANTIC SERIES LM 130 ALUM SLIDING GLASS DOOR  
**EGS INTERNATIONAL, LLC**  
 2799 SW 34th Avenue  
 Pembroke Park, FL 33023  
 Phone: (954) 519-7536 www.egsinternationalllc.com

revisions:	no.	date	by	description
	A	10.30.20		UPDATED TO 2020 FBC
	B	07.05.23		UPDATED TO 2023 FBC
date:	05-28-19			
scale:	3/8" = 1'-0"			
dr. by:	TARIQ			
chk. by:				
drawing no.	19-47F			
sheet	1 of 8			

COMP-ANL\19-47F-EGS

DESIGN LOAD CAPACITY - PSF (GLASS)						
PANEL WIDTH NOMINAL INCHES	DOOR HEIGHT INCHES	GLASS TYPE 'A' W/O REINF'D INTERLOCKS		GLASS TYPE 'B' WITH REINF'D INTERLOCKS		
		EXT.(+)	INT.(-)	EXT.(+)	INT.(-)	
24	84	80.0	135.0	105.0	130.0	
30		80.0	135.0	105.0	130.0	
36		80.0	135.0	105.0	130.0	
39-1/4		80.0	135.0	105.0	130.0	
42		80.0	135.0	105.0	130.0	
48		80.0	130.0	105.0	130.0	
50		76.8	124.8	100.8	124.8	
53		72.5	117.7	95.1	117.7	
56		68.6	111.4	90.0	111.4	
60		64.0	104.0	84.0	104.0	
24		90	80.0	135.0	105.0	130.0
30			80.0	135.0	105.0	130.0
36	80.0		135.0	105.0	130.0	
39-1/4	80.0		135.0	105.0	130.0	
42	80.0		135.0	105.0	130.0	
48	80.0		130.0	105.0	130.0	
50	76.8		124.8	100.8	124.8	
53	72.5		117.7	95.1	117.7	
56	68.6		111.4	90.0	111.4	
60	-		-	84.0	104.0	
24	96		80.0	135.0	105.0	130.0
30			80.0	135.0	105.0	130.0
36		80.0	135.0	105.0	130.0	
39-1/4		80.0	135.0	105.0	130.0	
42		80.0	130.0	105.0	130.0	
48		80.0	130.0	105.0	130.0	
50		76.8	124.8	100.8	124.8	
53		72.5	117.7	95.1	117.7	
56		-	-	90.0	111.4	
60		-	-	84.0	104.0	
24		102	80.0	130.0	105.0	130.0
30			80.0	130.0	105.0	130.0
36	80.0		130.0	105.0	130.0	
39-1/4	80.0		130.0	105.0	130.0	
42	80.0		130.0	105.0	130.0	
48	80.0		130.0	105.0	130.0	
50	76.8		124.8	100.8	124.8	
53	-		-	95.1	117.7	
56	-		-	90.0	111.4	
24	108		80.0	130.0	105.0	130.0
30			80.0	130.0	105.0	130.0
36			80.0	130.0	105.0	130.0
39-1/4		80.0	130.0	105.0	130.0	
42		80.0	130.0	105.0	130.0	
48		80.0	130.0	105.0	130.0	
50		-	-	100.8	124.8	
53		-	-	95.1	117.7	

DESIGN LOAD CAPACITY - PSF (GLASS)					
PANEL WIDTH NOMINAL INCHES	DOOR HEIGHT INCHES	GLASS TYPE 'A' W/O REINF'D INTERLOCKS		GLASS TYPE 'B' WITH REINF'D INTERLOCKS	
		EXT.(+)	INT.(-)	EXT.(+)	INT.(-)
24	114	-	-	105.0	130.0
30		-	-	105.0	130.0
36		-	-	105.0	130.0
39-1/4		-	-	105.0	130.0
42		-	-	105.0	130.0
48		-	-	105.0	130.0
50	-	-	100.8	124.8	
24	120	-	-	105.0	130.0
30		-	-	105.0	130.0
36		-	-	105.0	130.0
39-1/4		-	-	105.0	130.0
42		-	-	105.0	130.0
48		-	-	105.0	130.0

NOTE:  
GLASS CAPACITIES ON THIS SHEET ARE  
BASED ON ASTM E1300-09 (3 SEC. GUSTS)  
AND FLORIDA BUILDING COMMISSION  
DECLARATORY STATEMENT DCA05-DEC-219

DOOR SIZES TO COMPLY WITH FBC EGRESS REQUIREMENTS AS APPLICABLE.

PANEL WIDTH NOMINAL = OVERALL DOOR WIDTH  
NUMBER OF PANELS  
PANEL HEIGHT = DOOR HEIGHT - 2"  
MAX. OVERALL DOOR WIDTH ANY CONFIGURATION = 192"

(INTERPOLATION BETWEEN WIDTHS ALLOWED)

SHOWN CAPACITIES ARE FOR  
4.938" SILL HEIGHTS  
LIMIT EXTERIOR(+) LOADS AS FOLLOWS  
3.750" SILL HT. = +80.0 PSF  
3.188" SILL HT. = +53.3 PSF  
2.500" SILL HT. = SEE NOTE BELOW

2.500" SILL HEIGHTS CAN BE USED FOR INSTALLATIONS  
WHERE WATER INFILTRATION RESISTANCE IS NOT REQUIRED  
OR WHERE OVERHANG RATIO COMPLIES WITH FBC REQUIREMENTS.

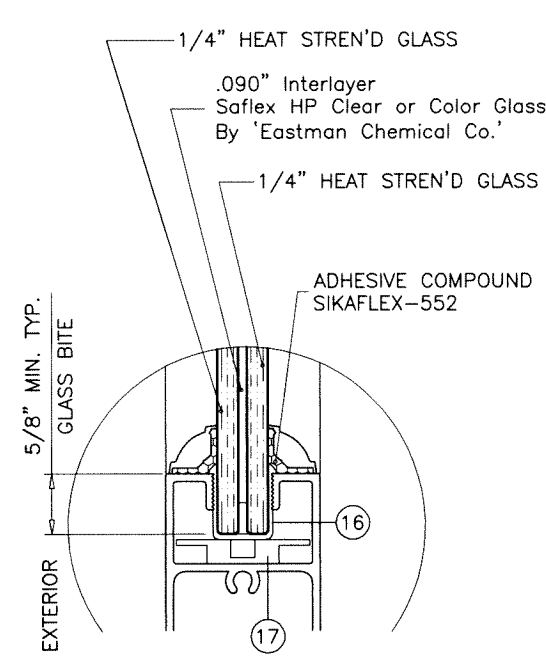

UPTO & INCLUDING 9'-0" HIGH DOORS  
GLASS TYPE 'A'

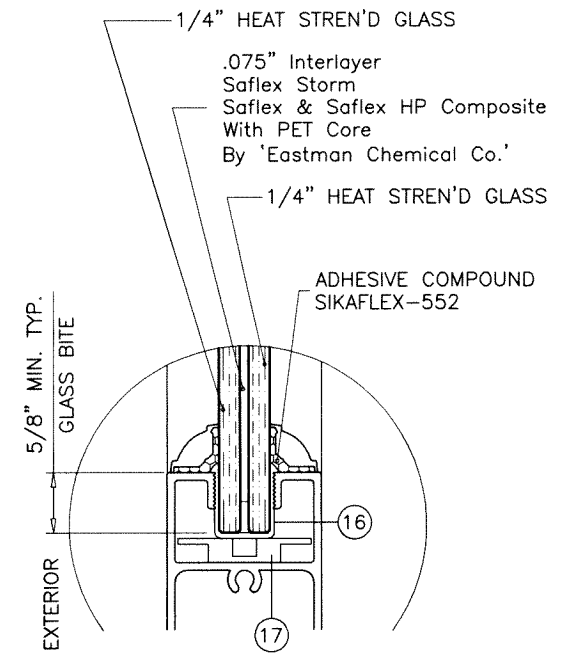

UPTO 10'-0" HIGH DOORS  
GLASS TYPE 'B'

GLAZING OPTIONS

Sealed: 7/12/2023

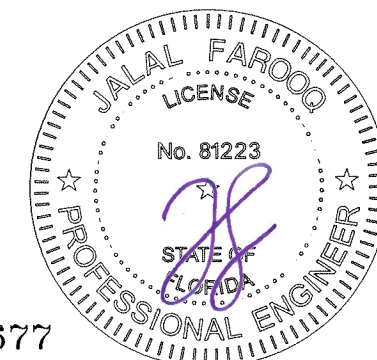

FL #29677

**AL-FAROOQ CORPORATION**  
ENGINEERS & PRODUCT DEVELOPMENT  
9360 SUNSET DRIVE, SUITE 220 (C.A.N. 3538)  
MIAMI, FLORIDA 33173 FAX. (305) 262-6978  
TEL. (305) 264-8100 COMP-ANL 19-47F-EGS

ATLANTIC SERIES LM 130 ALUM SLIDING GLASS DOOR  
**EGS INTERNATIONAL, LLC**  
2799 SW 34th Avenue  
Pembroke Park, FL 33023  
Phone: (954) 519-7536 www.egsinternationalllc.com

no	date	description

date: 05-28-19  
scale: 1/2"=1'-0"  
dr. by: TARIQ  
chk. by:

drawing no.  
**19-47F**  
sheet 2 of 8



HEAD ANCHOR LOAD CAPACITY - PSF				
ANCHOR TYPES		'A'	'B' & 'C'	
PANEL WIDTH NOMINAL INCHES	DOOR HEIGHT INCHES	6 ANCHORS AT MTG. STILE ENDS	4 ANCHORS AT MTG. STILE ENDS	6 ANCHORS AT MTG. STILE ENDS
		EXT. (+) INT. (-)	EXT. (+) INT. (-)	EXT. (+) INT. (-)
24	84	135.0	135.0	135.0
30		135.0	135.0	135.0
36		135.0	135.0	135.0
39-1/4		135.0	135.0	135.0
42		135.0	135.0	135.0
48		135.0	135.0	135.0
50		135.0	135.0	135.0
53		135.0	135.0	135.0
56		135.0	135.0	135.0
60		134.0	134.0	135.0
24	90	135.0	135.0	135.0
30		135.0	135.0	135.0
36		135.0	135.0	135.0
39-1/4		135.0	135.0	135.0
42		135.0	135.0	135.0
48		135.0	135.0	135.0
50		133.6	133.6	135.0
53		129.0	129.0	135.0
56		125.1	125.1	135.0
60		120.6	120.6	135.0
24	96	135.0	135.0	135.0
30		135.0	135.0	135.0
36		135.0	135.0	135.0
39-1/4		135.0	135.0	135.0
42		135.0	135.0	135.0
48		125.7	125.7	135.0
50		122.3	122.3	135.0
53		117.9	117.9	135.0
56		114.1	114.1	135.0
60		109.7	109.7	135.0
24	102	135.0	135.0	135.0
30		135.0	135.0	135.0
36		135.0	135.0	135.0
39-1/4		134.3	134.3	135.0
42		127.7	127.7	135.0
48		116.0	116.0	135.0
50		112.8	112.8	135.0
53		108.5	108.5	135.0
56		104.8	104.8	135.0
24		108	135.0	135.0
30	135.0		135.0	135.0
36	134.0		134.0	135.0
39-1/4	125.2		125.2	135.0
42	118.9		118.9	135.0
48	107.7		107.7	135.0
50	104.7		104.7	135.0
53	100.5		100.5	135.0

HEAD ANCHOR LOAD CAPACITY - PSF					
ANCHOR TYPES		'A'	'B' & 'C'		
PANEL WIDTH NOMINAL INCHES	DOOR HEIGHT INCHES	6 ANCHORS AT MTG. STILE ENDS	4 ANCHORS AT MTG. STILE ENDS	6 ANCHORS AT MTG. STILE ENDS	
		EXT. (+) INT. (-)	EXT. (+) INT. (-)	EXT. (+) INT. (-)	
24	114	135.0	135.0	135.0	
30		135.0	135.0	135.0	
36		125.7	125.7	135.0	
39-1/4		117.2	117.2	135.0	
42		111.2	111.2	135.0	
48		100.5	100.5	135.0	
50		97.6	97.6	135.0	
24		120	135.0	135.0	135.0
30			135.0	135.0	135.0
36			118.3	118.3	135.0
39-1/4	110.2		110.2	135.0	
42	104.5		104.5	135.0	
48	94.3		94.3	135.0	

SILL ANCHOR LOAD CAPACITY - PSF			
ANCHOR TYPE		'B'	
PANEL WIDTH NOMINAL INCHES	DOOR HEIGHT INCHES	4 ANCHORS AT MTG. STILE ENDS	6 ANCHORS AT MTG. STILE ENDS
		EXT. (+) INT. (-)	EXT. (+) INT. (-)
24	84	135.0	135.0
30		135.0	135.0
36		135.0	135.0
39-1/4		135.0	135.0
42		135.0	135.0
48		135.0	135.0
50		135.0	135.0
53		135.0	135.0
56		135.0	135.0
60		134.0	135.0
24	90	135.0	135.0
30		135.0	135.0
36		135.0	135.0
39-1/4		135.0	135.0
42		135.0	135.0
48		135.0	135.0
50		133.6	135.0
53		129.0	135.0
56		125.1	135.0
60		120.6	135.0
24	96	135.0	135.0
30		135.0	135.0
36		135.0	135.0
39-1/4		135.0	135.0
42		135.0	135.0
48		125.7	135.0
50		122.3	135.0
53		117.9	135.0
56		114.1	135.0
60		109.7	135.0
24	102	135.0	135.0
30		135.0	135.0
36		135.0	135.0
39-1/4		134.3	135.0
42		127.7	135.0
48		116.0	135.0
50		112.8	135.0
53		108.5	135.0
56		104.8	135.0
24		108	135.0
30	135.0		135.0
36	134.0		135.0
39-1/4	125.2		135.0
42	118.9		135.0
48	107.7		135.0
50	104.7		135.0
53	100.5		135.0

SILL ANCHOR LOAD CAPACITY - PSF				
ANCHOR TYPE		'B'		
PANEL WIDTH NOMINAL INCHES	DOOR HEIGHT INCHES	4 ANCHORS AT MTG. STILE ENDS	6 ANCHORS AT MTG. STILE ENDS	
		EXT. (+) INT. (-)	EXT. (+) INT. (-)	
24	114	135.0	135.0	
30		135.0	135.0	
36		125.7	135.0	
39-1/4		117.2	135.0	
42		111.2	135.0	
48		100.5	135.0	
50		97.6	135.0	
24		120	135.0	135.0
30			135.0	135.0
36			118.3	135.0
39-1/4	110.2		135.0	
42	104.5		135.0	
48	94.3		135.0	

**TYPICAL ANCHORS:** SEE ELEV. FOR SPACING

**AT HEAD**

**TYPE 'A' - 1/4" DIA. ULTRACON+ BY 'DEWALT'** (Fu=164 KSI, Fy=148 KSI)  
 INTO 2BY WOOD BUCKS OR WOOD STRUCTURES  
 1-1/2" MIN. PENETRATION INTO WOOD  
 THRU 1BY BUCKS INTO CONCRETE  
 1-1/4" MIN. EMBED INTO CONCRETE

**TYPE 'B' - 1/4" DIA. ULTRACON+ BY 'DEWALT'** (Fu=164 KSI, Fy=148 KSI)  
 DIRECTLY INTO CONCRETE  
 1-3/4" MIN. EMBED

**TYPE 'C' - 1/4" DIA. SELF DRILLING SCREWS** (GRADE 5 CRS)  
 INTO F.B.C. APPROVED MULLIONS  
 OR  
 INTO METAL STRUCTURES (HEAD/JAMBS)  
 (3) THREADS MIN. TO EXTEND BEYOND METAL THICKNESS  
 ALUMINUM: 1/8" THK. MIN. (6063-T5 MIN.)  
 STEEL: 1/8" THK. MIN. (Fy = 36 KSI MIN.)  
 (STEEL IN CONTACT WITH ALUMINUM TO BE PLATED OR PAINTED)

**AT SILL**

**TYPE 'B' - 1/4" DIA. ULTRACON+ BY 'DEWALT'** (Fu=164 KSI, Fy=148 KSI)  
 DIRECTLY INTO CONCRETE  
 1-3/4" MIN. EMBED

**AT JAMBS**

**TYPE 'D' - 1/4" DIA. ULTRACON+ BY 'DEWALT'** (Fu=164 KSI, Fy=148 KSI)  
 THRU 1BY BUCKS INTO BLOCKS  
 1-1/4" MIN. EMBED INTO BLOCKS  
 DIRECTLY INTO BLOCKS  
 1-1/4" MIN. EMBED INTO BLOCKS

**TYPE 'E' - 1/4" DIA. ULTRACON+ BY 'DEWALT'** (Fu=164 KSI, Fy=148 KSI)  
 INTO 2BY WOOD BUCKS OR WOOD STRUCTURES  
 1-1/2" MIN. PENETRATION INTO WOOD  
 THRU 1BY BUCKS INTO CONCRETE  
 1-1/4" MIN. EMBED INTO CONCRETE  
 DIRECTLY INTO CONCRETE  
 1-3/4" MIN. EMBED INTO CONCRETE

**TYPE 'F' - #14 SMS OR SELF DRILLING SCREWS** (GRADE 5 CRS)  
 INTO F.B.C. APPROVED MULLIONS  
 OR  
 INTO METAL STRUCTURES (HEAD/JAMBS)  
 (3) THREADS MIN. TO EXTEND BEYOND METAL THICKNESS  
 ALUMINUM: 1/8" THK. MIN. (6063-T5 MIN.)  
 STEEL: 1/8" THK. MIN. (Fy = 36 KSI MIN.)  
 (STEEL IN CONTACT WITH ALUMINUM TO BE PLATED OR PAINTED)

**ANCHOR EDGE DISTANCES**

INTO CONCRETE = 2-1/2" MIN.  
 INTO WOOD STRUCTURE = 1" MIN.  
 INTO METAL STRUCTURE = 3/4" MIN.

WOOD AT HEAD OR JAMBS SG = 0.55 MIN.  
 CONCRETE AT HEAD, SILL OR JAMBS f'c = 3000 PSI MIN.  
 C-90 HOLLOW/FILLED BLOCK AT JAMBS f'm = 2000 PSI MIN.

Sealed: 7/12/2023

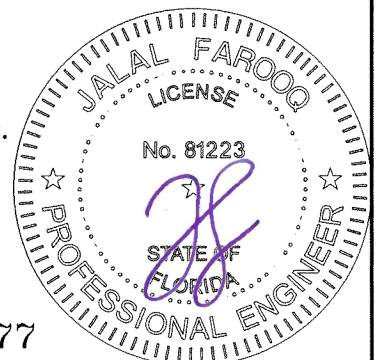

PANEL WIDTH NOMINAL = OVERALL DOOR WIDTH / NUMBER OF PANELS

PANEL HEIGHT = DOOR HEIGHT - 2"

FL #29677

**AL-FAROOQ CORPORATION**  
 ENGINEERS & PRODUCT DEVELOPMENT  
 9360 SUNSET DRIVE, SUITE 220  
 MIAMI, FLORIDA 33173  
 TEL. (305) 264-8100 FAX. (305) 262-6978  
 (C.A.N. 3638)

ATLANTIC SERIES LM 130 ALUM SLIDING GLASS DOOR  
**EGS INTERNATIONAL, LLC**  
 2799 SW 34th Avenue  
 Pembroke Park, FL 33023  
 Phone: (954) 519-7536 www.egsinternational.com

revisions:	no	date	by	description
date:	05-28-19	scale:	1/2" = 1'-0"	
dr. by:	TARIQ	chk. by:		
drawing no.	19-47F			
sheet	3 of 8			

COMP-ANL 19-47F-EGS

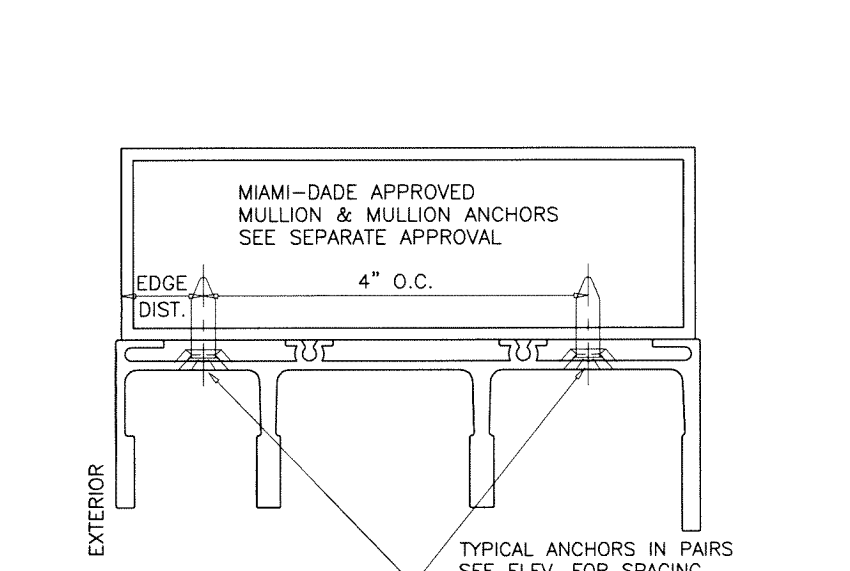
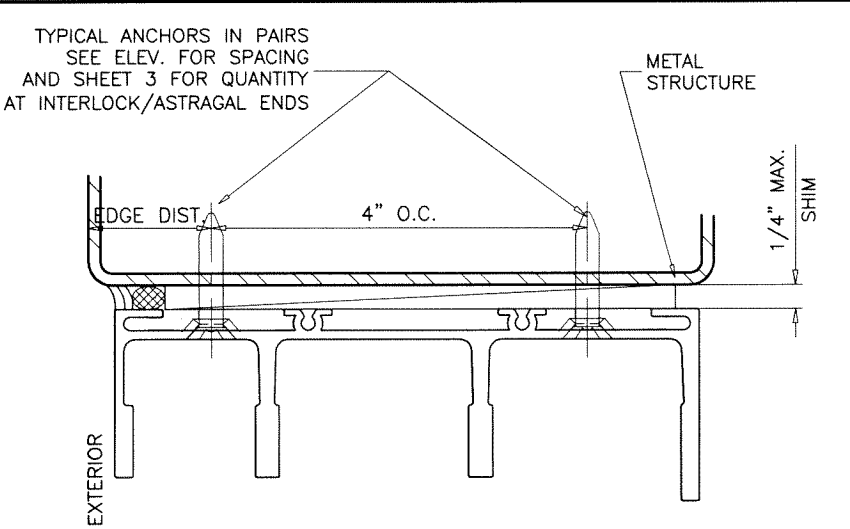
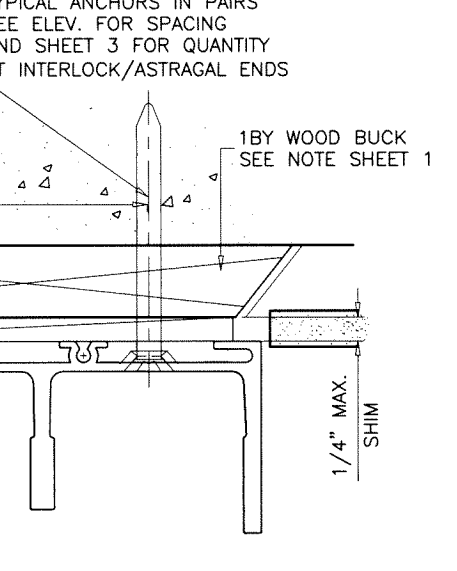
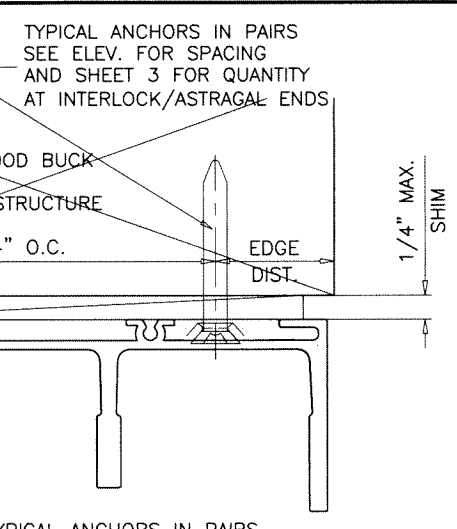
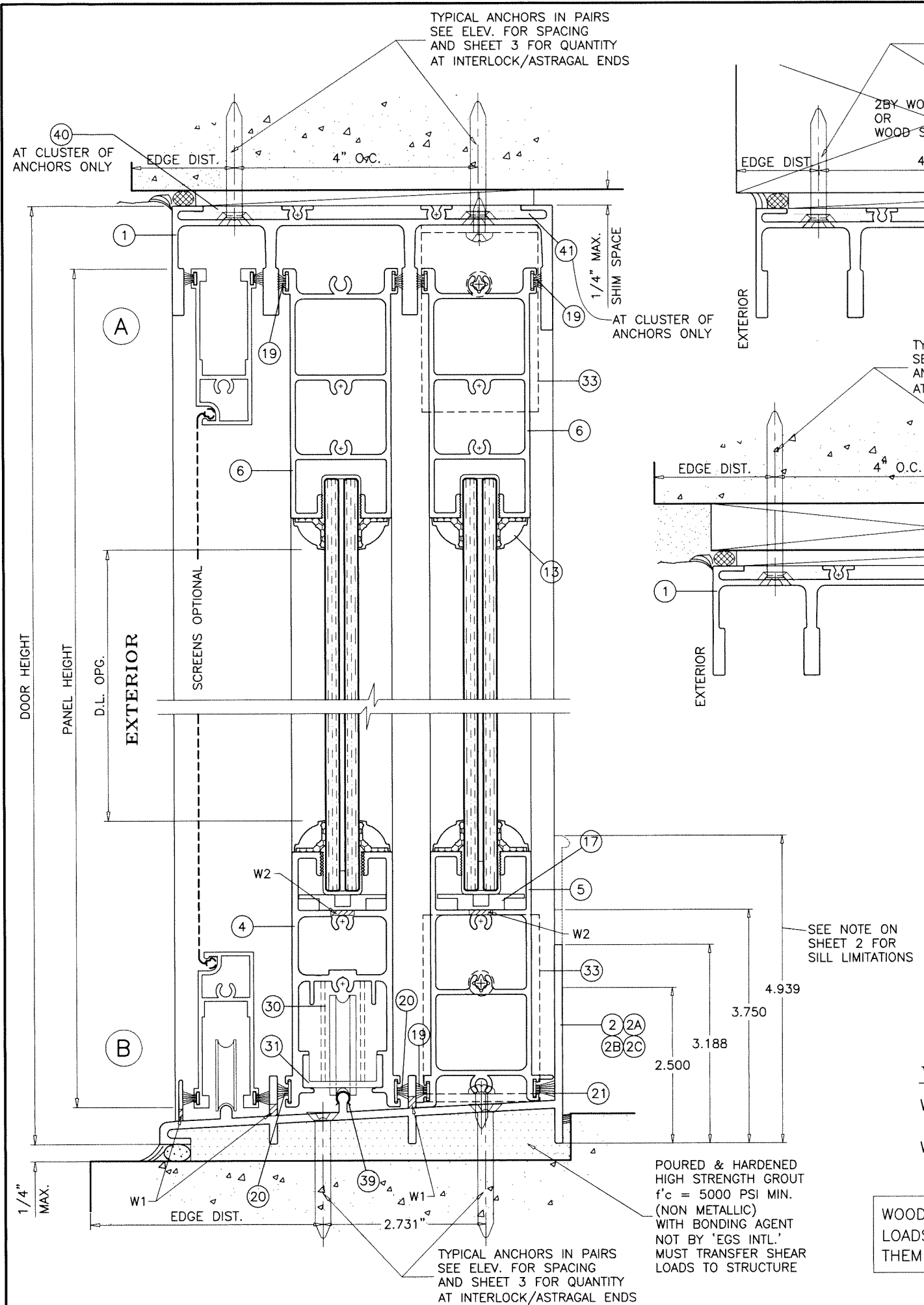

**WEEPHOLES:**  
W1 = 3/16" H X 3/4" W WEEP SLOTS AT QUARTER POINTS OF EACH PANEL  
W2 = 3/8" WEEP HOLE AT 6" FROM ENDS AND CENTER OF EACH RAIL

WOOD BUCKS NOT BY 'EGS INTL.', MUST SUSTAIN LOADS IMPOSED BY GLAZING SYSTEM AND TRANSFER THEM TO THE BUILDING STRUCTURE.

**SEALANT:**  
ALL JOINTS AND FRAME CONNECTIONS SEALED WITH WHITE/ALUMINUM COLORED SILICONE.  
MAJOR INTERLOCK STILES TOP AND BOTTOM ENDS FILLED WITH EXPANDING URETHANE FOAM.  
ALL INSTALLATION ANCHOR HEADS TO BE SEALED & EXPOSED ANCHORS TO BE CAPPED WITH ALUM. BUTTON COVERS.

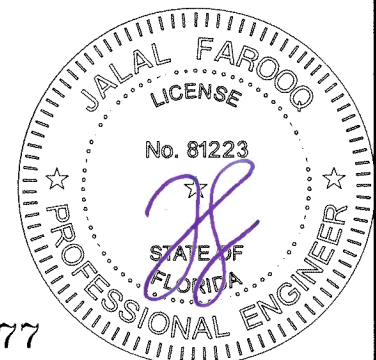

Sealed: 7/12/2023

FL #29677

**AL-FAROOQ CORPORATION**  
ENGINEERS & PRODUCT DEVELOPMENT  
9360 SUNSET DRIVE, SUITE 220  
MIAMI, FLORIDA 33173 (C.A.N. 3538)  
TEL. (305) 264-8100 FAX. (305) 262-6978  
COMP-ANL \ 19-47F-EGS

ATLANTIC SERIES LM 130 ALUM SLIDING GLASS DOOR  
**EGS INTERNATIONAL, LLC**  
2799 SW 34th Avenue  
Pembroke Park, FL 33023  
Phone: (954) 519-7536 www.egsinternational.com

no	date	description

date: 05-28-19  
scale: 1/2" = 1"  
dr. by: TARIQ  
chk. by:   
drawing no. 19-47F  
sheet 4 of 8



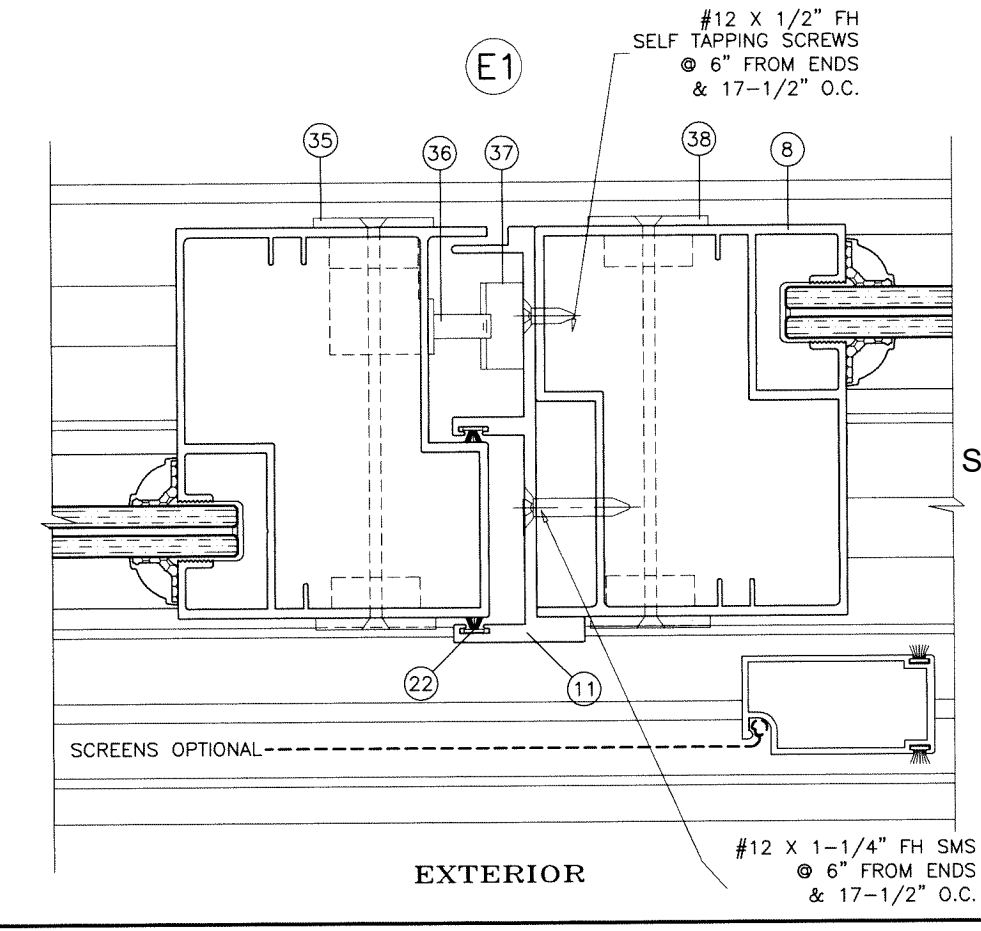
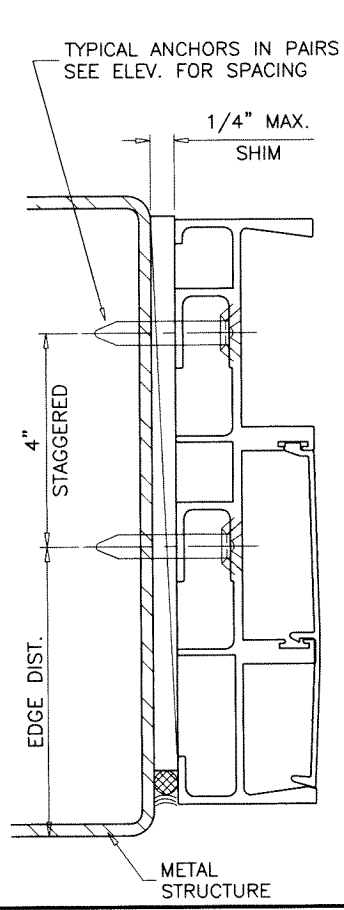
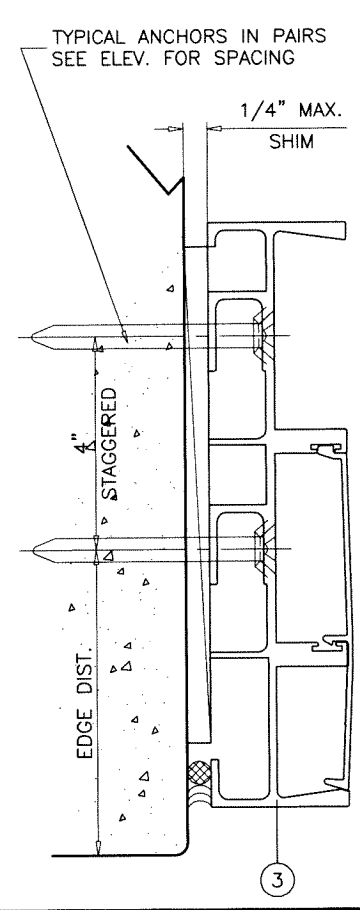
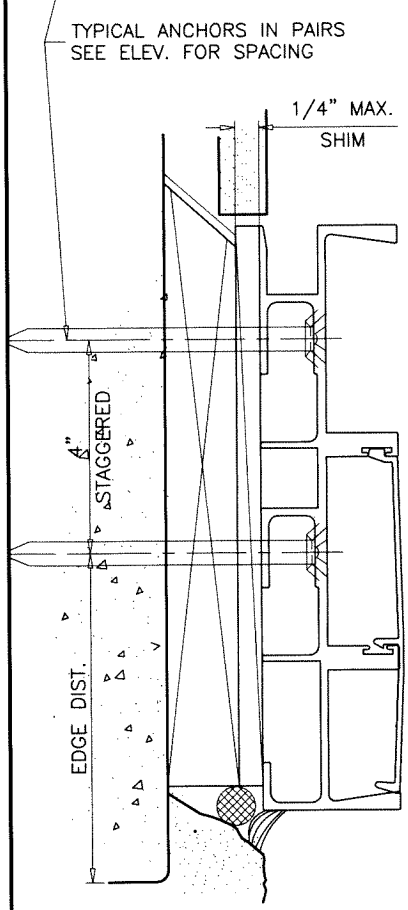
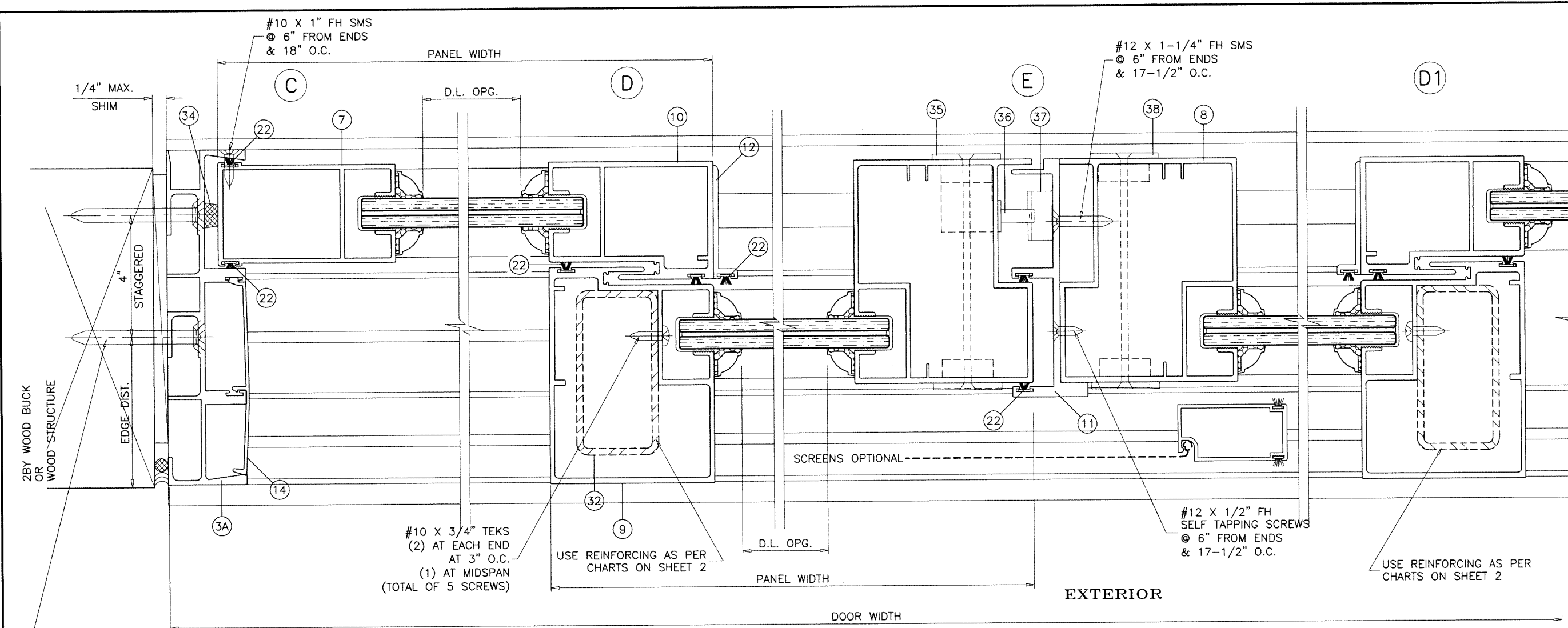

Sealed: 7/12/2023

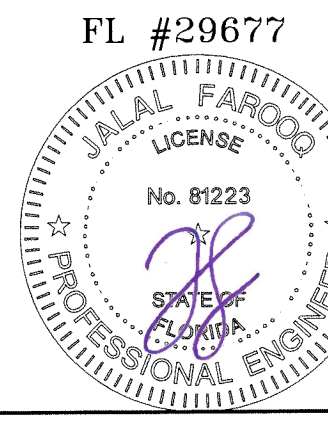

**af c**  
**AL-FAROOQ CORPORATION**  
 ENGINEERS & PRODUCT DEVELOPMENT  
 9360 SUNSET DRIVE, SUITE 220 (C.A.N. 3538)  
 MIAMI, FLORIDA 33173 TEL. (305) 264-8100 FAX. (305) 262-6978  
 COMP-ANL\19-47F-EGS

ATLANTIC SERIES LM 130 ALUM SLIDING GLASS DOOR  
**EGS INTERNATIONAL, LLC**  
 2799 SW 34th Avenue  
 Pembroke Park, FL 33023  
 Phone: (954) 519-7536 www.egsinternational.com

revisions:	no	date	description

date: 05-28-19  
 scale: 1/2" = 1"  
 dr. by: TARIO  
 chk. by:

drawing no.  
**19-47F**

sheet 5 of 8

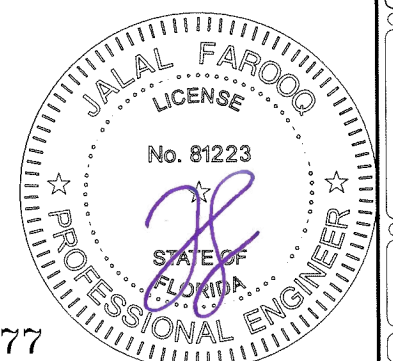
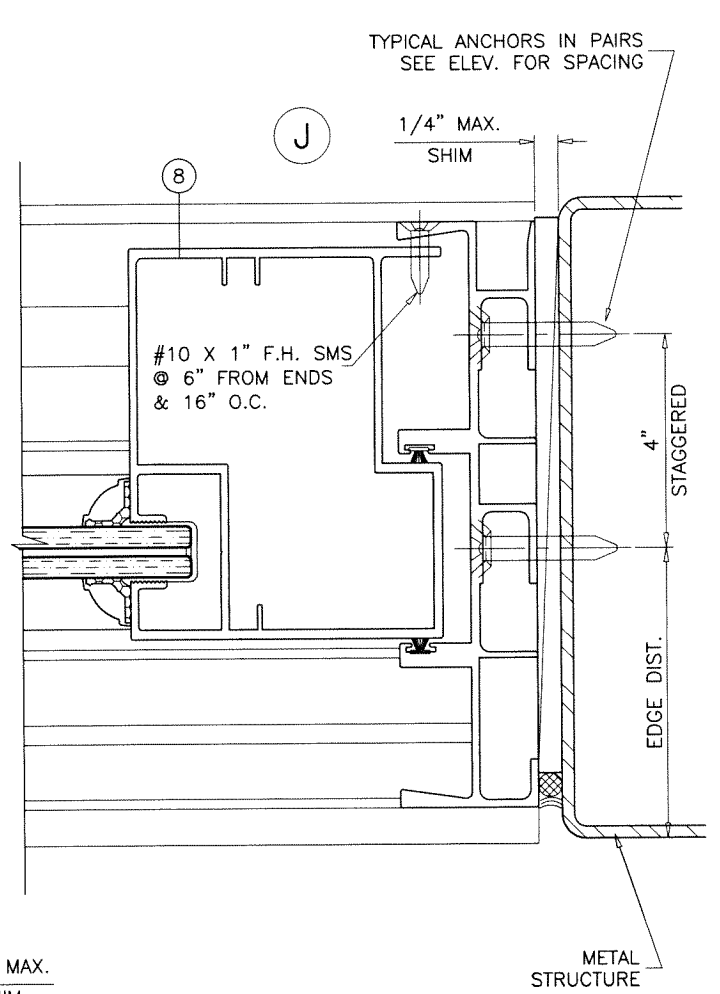
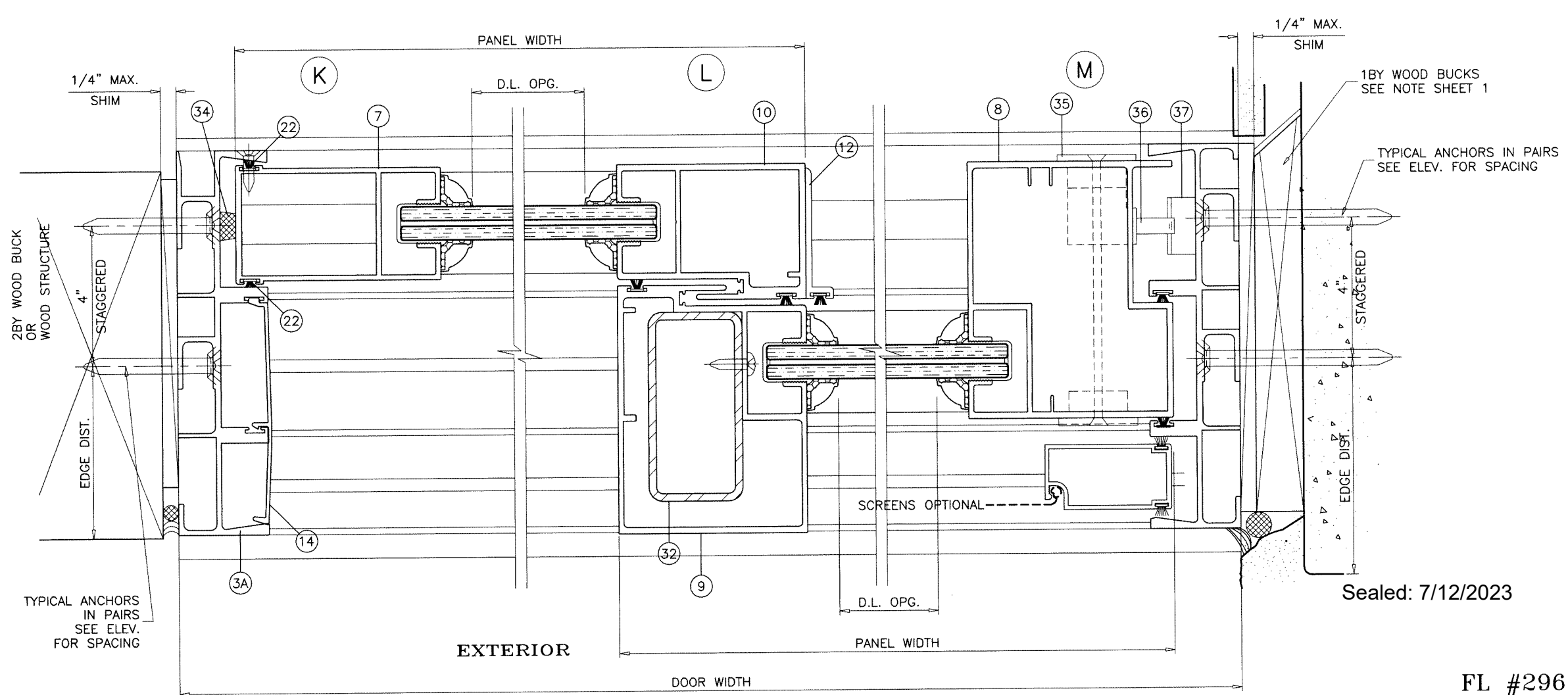

Sealed: 7/12/2023

FL #29677

**afc**  
**AL-FAROOQ CORPORATION**  
 ENGINEERS & PRODUCT DEVELOPMENT  
 9360 SUNSET DRIVE, SUITE 220 (C.A.N. 3538)  
 MIAMI, FLORIDA 33173  
 TEL. (305) 264-8100 FAX. (305) 262-6978  
 COMP-ANL\19-47F-EGS

ATLANTIC SERIES LM 130 ALUM SLIDING GLASS DOOR  
**EGS INTERNATIONAL, LLC**  
 2799 SW 34th Avenue  
 Pembroke Park, FL 33023  
 Phone: (954) 519-7536 www.egsinternationalllc.com

revisions:	no	date	description

date: 05-28-19	scale: 1/2" = 1"	dr. by: TARIQ	chk. by:
drawing no. 19-47F			
sheet 6 of 8			

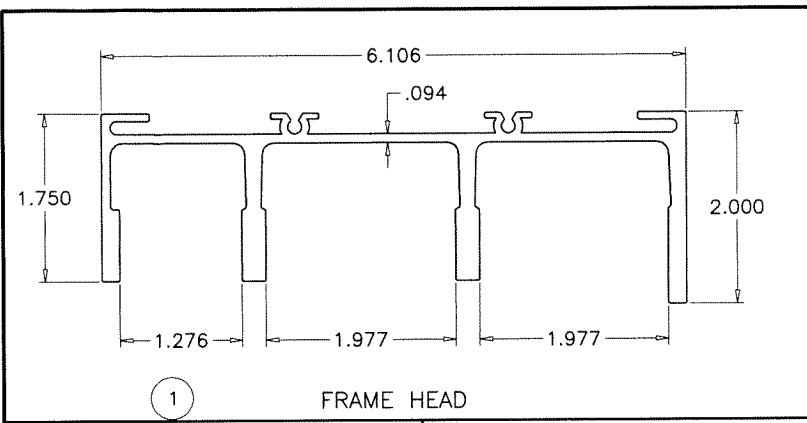

1 FRAME HEAD

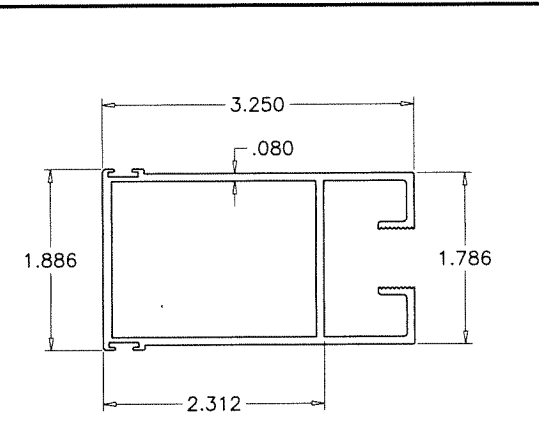

7 FIXED STILE

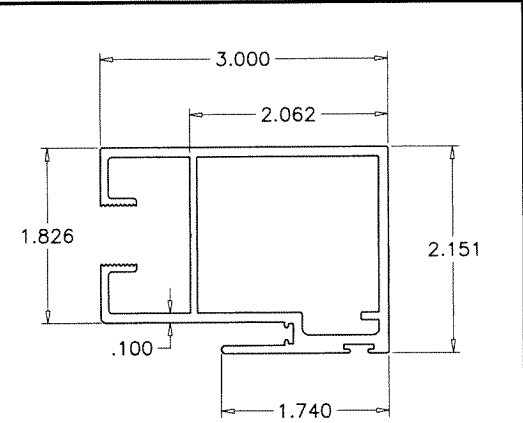

10 MINOR INTERLOCK

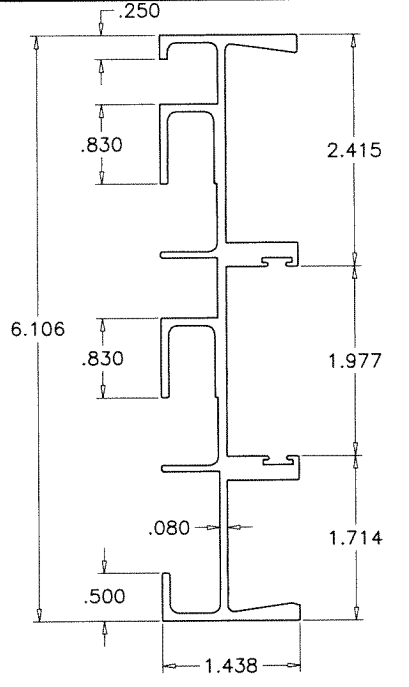

3 FRAME JAMB W/O POCKET

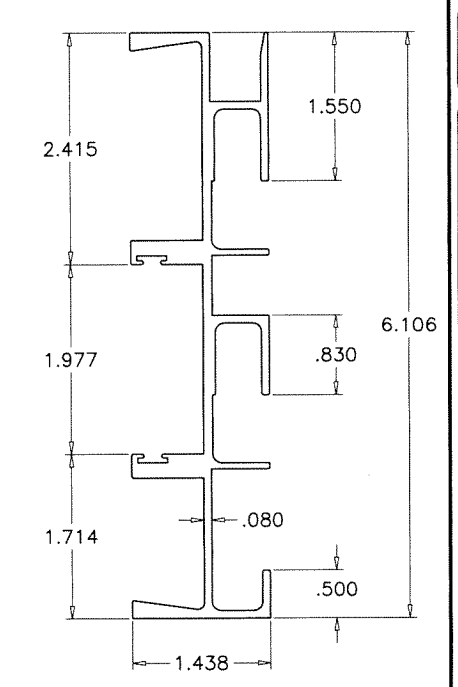

3A FRAME JAMB WITH POCKET

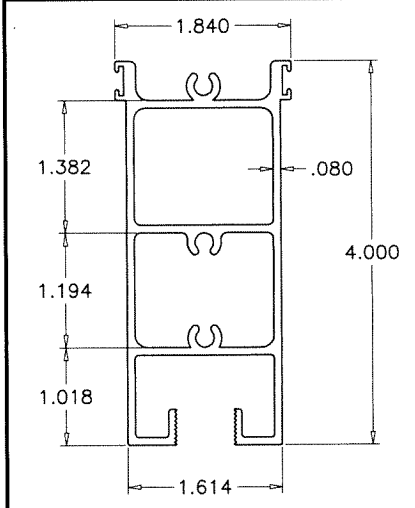

6 TOP RAIL

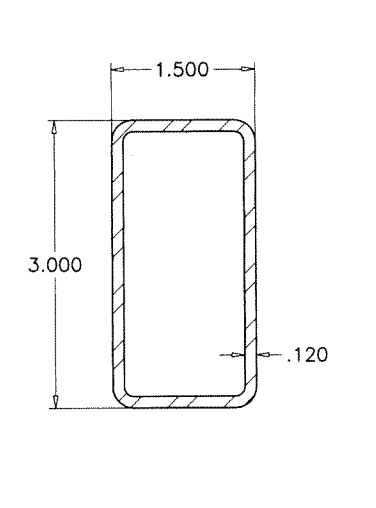

32 REINFORCING TUBE

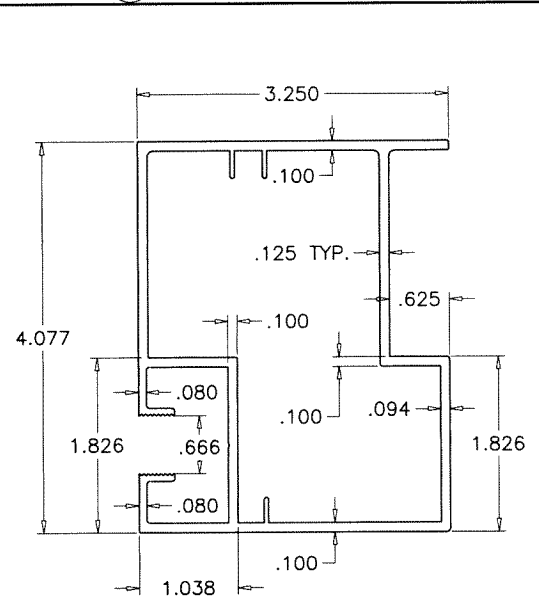

8 LOCKING STILE

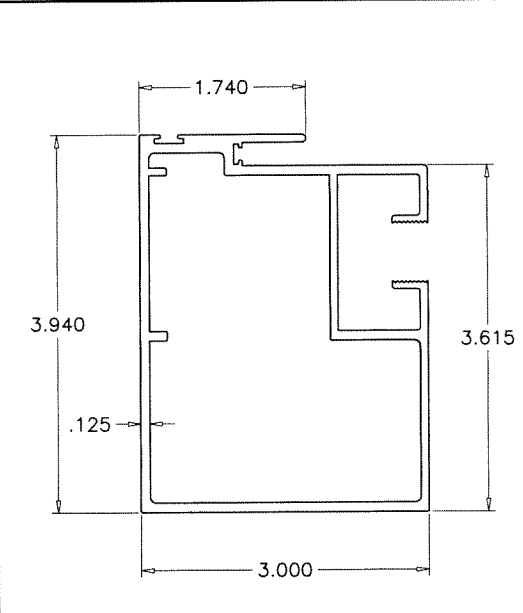

9 MAJOR INTERLOCK

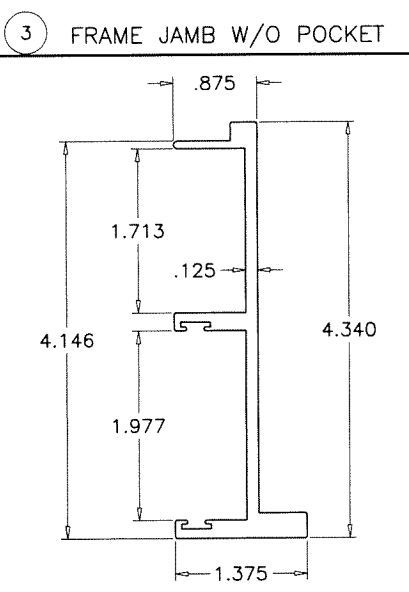

11 STILE ADAPTER

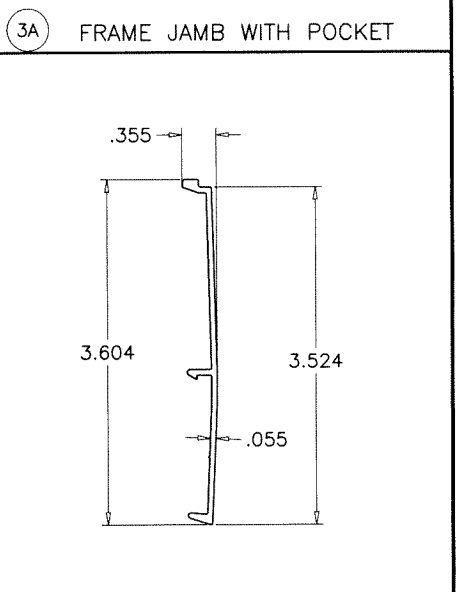

14 JAMB COVER

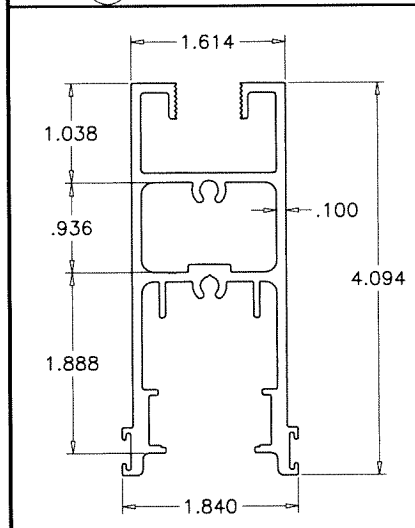

4 MOVING BOTTOM RAIL

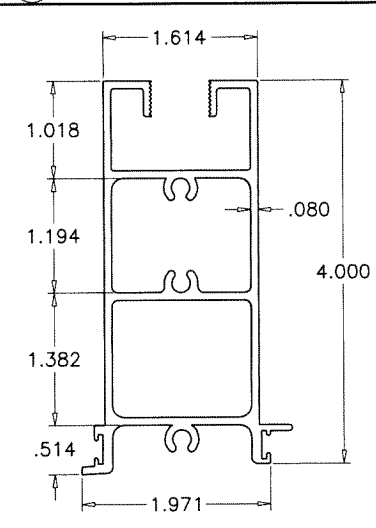

5 FIXED BOTTOM RAIL

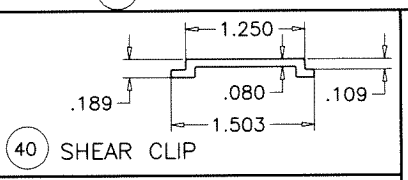

40 SHEAR CLIP

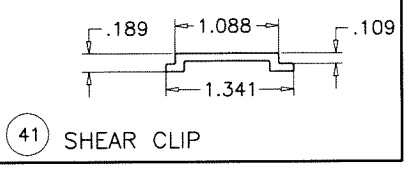

41 SHEAR CLIP

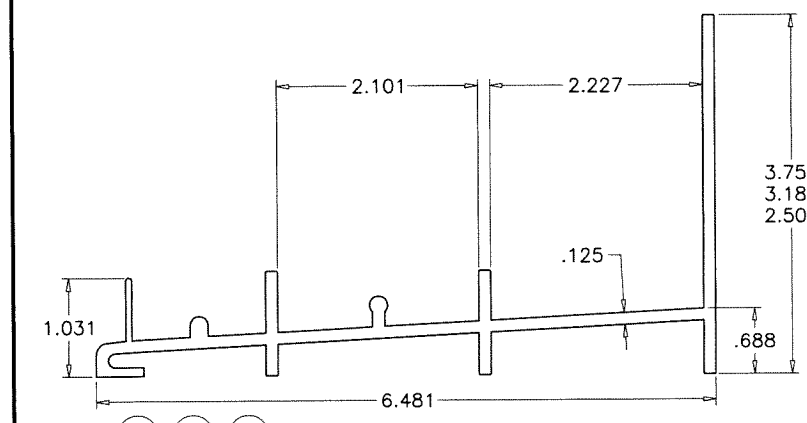

2 2A 2C FRAME SILL

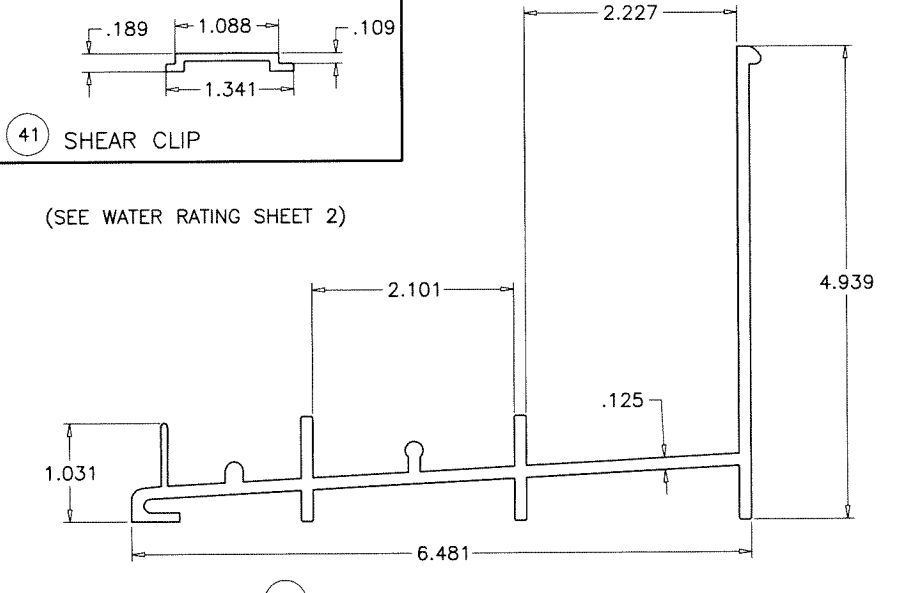

2B FRAME SILL

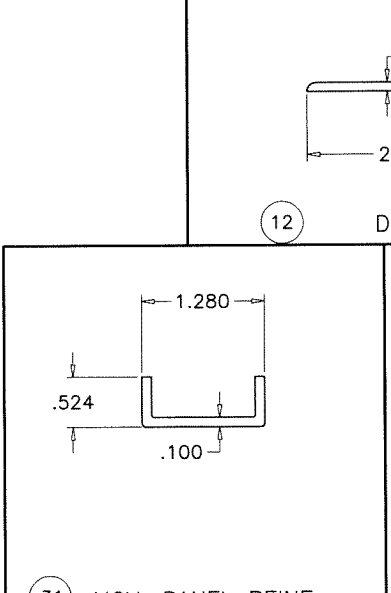

31 MOV. PANEL REINF.

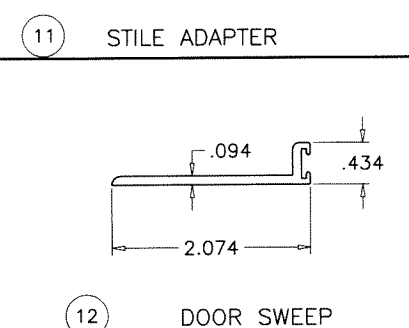

12 DOOR SWEEP

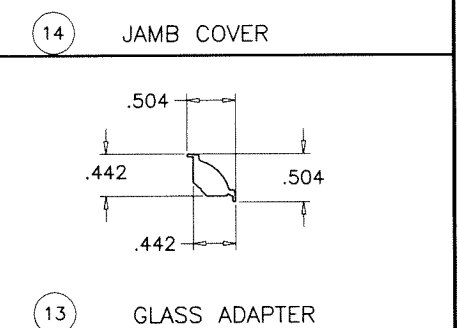

13 GLASS ADAPTER

Sealed: 7/12/2023

FL #29677

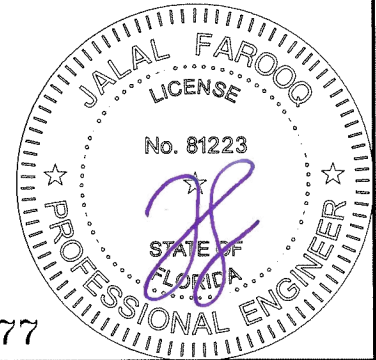

**AL-FAROOQ CORPORATION**  
 ENGINEERS & PRODUCT DEVELOPMENT  
 9360 SUNSET DRIVE, SUITE 220  
 MIAMI, FLORIDA 33173 (C.A.N. 3538)  
 TEL. (305) 264-8100 FAX. (305) 262-6978  
 COMP-ANL\19-47F-EGS

ATLANTIC SERIES LM 130 ALUM SLIDING GLASS DOOR  
**EGS INTERNATIONAL, LLC**  
 2799 SW 34th Avenue  
 Pembroke Park, FL 33023  
 Phone: (954) 519-7536 www.egsinternationalllc.com

no	date	by	description

date: 05-28-19  
 scale: 1/2" = 1"  
 dr. by: TARIQ  
 chk. by:

drawing no.  
**19-47F**  
 sheet 7 of 8



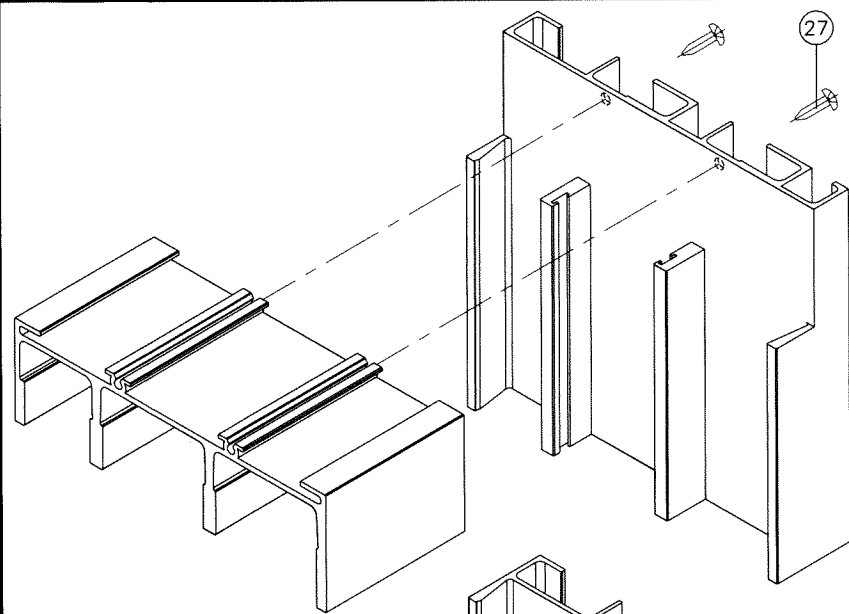

FRAME TOP CORNER

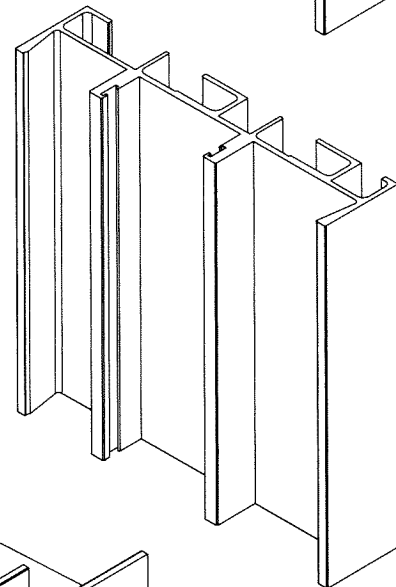

FRAME BOTTOM CORNER

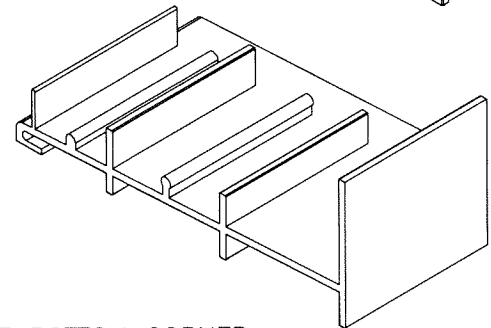

PANEL CORNER

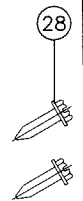

ITEM NO.	PART NUMBER	QUANTITY	DESCRIPTION	MATERIAL	MANF./SUPPLIER/REMARKS
1	EGS-551	1	FRAME HEAD	6005-T5/6105-T5	-
2	EGS-580	1	FRAME SILL (3-3/16" HIGH)	6005-T5/6105-T5	-
2A	EGS-581	1	FRAME SILL (3-3/4" HIGH)	6005-T5/6105-T5	-
2B	EGS-552	1	FRAME SILL (4-15/16" HIGH)	6005-T5/6105-T5	-
2C	EGS-580	1	FRAME SILL (2-1/2" HIGH)	6005-T5/6105-T5	-
3	EGS-567	2	FRAME JAMB W/O POCKET	6005-T5/6105-T5	-
3A	EGS-553	2	ALT. FRAME JAMB W/ POCKET	6005-T5/6105-T5	-
4	EGS-573	1/MOV. PANEL	MOVING HORIZ. BOTT. RAIL	6005-T5/6105-T5	-
5	EGS-572	1/FIX. PANEL	FIXED HORIZ. BOTT. RAIL	6005-T5/6105-T5	-
6	EGS-571	1/PANEL	TOP RAIL	6005-T5/6105-T5	-
7	EGS-574	AS REQD.	FIXED STILE	6005-T5/6105-T5	-
8	EGS-575	AS REQD.	LOCKING STILE	6005-T5/6105-T5	-
9	EGS-576	AS REQD.	MAJOR INTERLOCK	6005-T5/6105-T5	-
10	EGS-577	AS REQD.	MINOR INTERLOCK	6005-T5/6105-T5	-
11	EGS-561	AS REQD.	STILE ADAPTER	6005-T5/6105-T5	-
12	EGS-566	AS REQD.	DOOR SWEEP	6063-T5/6105-T5	AT TOP OF MOV. PANEL
13	EGS-579	AS REQD.	GLASS ADAPTER	6063-T5/6105-T5	-
14	EGS-570	AS REQD.	JAMB COVER	6063-T5/6105-T5	-
16	EGS-72	AS REQD.	9/16" GLAZING GASKET	SOFT PVC	TEAMPLASTICS (BVC INC.)
17	TX11429E	2/ LITE	SETTING BLOCKS, 4" LONG, @ 10" FROM EACH END	EPDM	TREMCO
19	28027045/7527-6011-4	AS REQD.	FINSEAL WOOLPILE AT HORIZ. RAILS	-	AMESBURY
20	T-2836G	AS REQD.	POLYBOND FINSEAL AT MOV. BOTTOM RAIL	-	ULTRAFAB (.280H X .360 BASE)
21	38027045/7537-6011-6	AS REQD.	FINSEAL WOOLPILE AT FIX. BOTTOM RAIL	-	AMESBURY
22	21027045/7420-6011-2	AS REQD.	FINSEAL WOOLPILE AT VERT. STILES & SWEEP	-	AMESBURY
27	#8 X 3/4"	2/ CORNER	FRAME ASSEMBLY SCREWS	ST. STEEL	PH SMS
28	#12 X 1"	2/ CORNER	PANEL ASSEMBLY SCREWS	ST. STEEL	TH SMS
30	-	2/ MOV. PANEL	TANDEM ACETAL WHEELS IN METALLIC HOUSING	-	DUAL ROLLERS
31	-	1/ MOV. PANEL	ALUM CHANNEL, FULL WIDTH OF PANEL	6063-T5/6105-T5	-
32	-	AS REQD.	INTERLOCK REINFORCEMENT	STEEL	1 1/2" X 3" X 11 G.A.
33	-	AS REQD.	FIX. PANEL CLIP (AT FRAME HEAD/SILL)	ALUMINUM	2 X 3 X 1/8" X 1-7/8" LONG
34	-	AS REQD.	RUBBER BUMPER	-	1/2" X 1/2" SQ. X 3/16" HIGH
35	4430-00-08 OR W5208-NPV30	1	TRIMSET PULL	ABS RESIN OR BRASS (PVD)	ADAMS-RITE OR ASHLAND
36	MS1847-09	1	DEAD LOCK, MOUNTED W/ (2) #6 X 1/4" FH SCREWS	ST. STEEL	ADAMS-RITE
37	4801-05	1	STRIKE, MOUNTED W/ (2) #8 X 1" PH SCREWS & PLASTIC SHIM	ST. STEEL	ADAMS-RITE
38	4432 OR W5208-PP30	1	DUMMY TRIMSET PULL	ABS RESIN OR BRASS (PVD)	ADAMS-RITE OR ASHLAND
39	TC2	1	TRACK COVER	ST/ST	HYGRADE
40	-	AS REQD.	SHEAR CLIP AT CLUSTERS ONLY	6005-T5/6105-T5	-
41	-	AS REQD.	SHEAR CLIP AT CLUSTERS ONLY	6005-T5/6105-T5	-

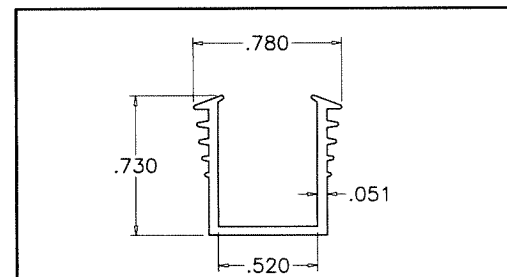

HARDNESS = 85 SHORE A  
 TENSILE STRENGTH (BREAK) = 1810 PSI  
 ELONGATION AT BREAK = 320%  
 TEAR STRENGTH = 260 LBF/IN  
 SPECIFIC GRAVITY = 1.45

GLAZING GASKET  
 SCALE 1:1

16

Sealed: 7/12/2023

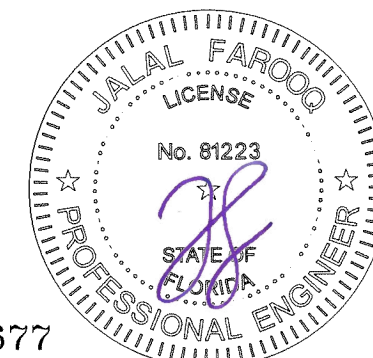

FL #29677

**af c**  
**AL-FAROOQ CORPORATION**  
 ENGINEERS & PRODUCT DEVELOPMENT  
 9360 SUNSET DRIVE, SUITE 220 (C.A.N. 3538)  
 MIAMI, FLORIDA 33173 FAX. (305) 262-6978  
 TEL. (305) 264-8100

ATLANTIC SERIES LM 130 ALUM SLIDING GLASS DOOR  
**EGS INTERNATIONAL, LLC**  
 2799 SW 34th Avenue  
 Pembroke Park, FL 33023  
 Phone: (954) 519-7536 www.egsinternationalllc.com

revisions:	no	date	by	description

date: 05-28-19  
 scale: 1/2" = 1"  
 dr. by: TARIQ  
 chk. by:  
 drawing no.  
**19-47F**  
 sheet 8 of 8

COMP-ANL \ 19-47F-EGS